



SPRAYERS
& EQUIPMENT

TRS 3-ROW R-SERIES SPRAYER



TRS 3-ROW R-SERIES SPRAYER

MODEL NAME: R3-2300, R3-3000, R3-4000

The TRS R-Series Recycling Vineyard Sprayer takes a great concept and makes it even better! Building on the original award winning FMR R-Series sprayer released in 2010, the TRS machine introduces a number of new features and innovations that make owning and operating this machine in your vineyard even more beneficial.

Features include:

- Shroud design with fold down sump in base for rapid cleaning of filtration screens
- Shroud design is quickly and easily dismantled for ease of servicing
- Tank design provides improved weight distribution for stability
- New boom system provides improved functionality and flexibility
- Pumps and valves slide or fold out, making servicing simple and easy
- Overall maneuverability and stability improved with overall height and length reduced and centre of mass lowered
- New heavy duty walking beam axle system
- Improved tank level indicator located on rear frame
- Improved hydraulic system for greater efficiency and function
- Auto rate controller for improved operator comfort and control

FEATURES:

- Composite tank - 2300L, 3000L, 4000L options
- 200lt fresh water for flushing & hand wash
- Hot dip galvanised chassis & boom
- Weber tangential fans with 8 nozzle wet boom
- Automatic rate controller
- Proven R-Series delivery & recycling technology
- 100% hydraulic drive - just 77lt/min required

BENEFITS:

- Addresses the environmental and social issues from off-target drift
- Enables savings of 25-40% of annual spray expenditure
- Huge savings in time from reduced refill occasions
- Increased application opportunity due to ability to operate in inclement weather conditions
- Multiple systems for enhanced operator comfort and safety

ADDITIONAL OPTIONS:

- 3-point pivoting hitch
- Hydraulic brakes

MODEL DIMENSIONS:

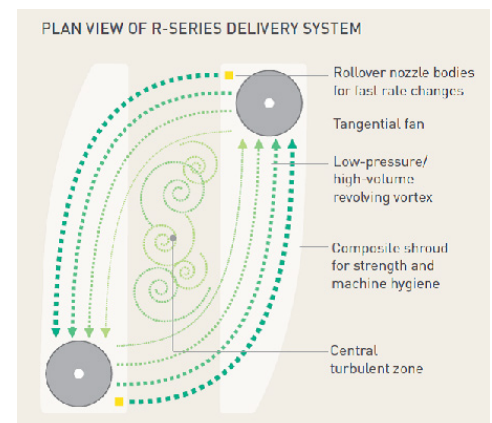
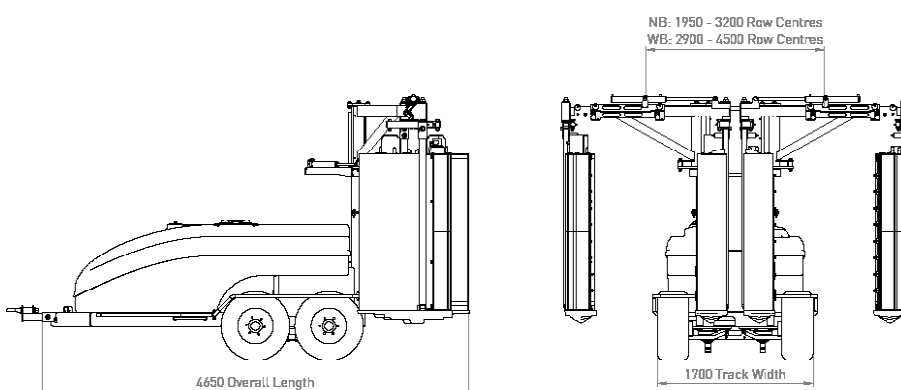

Distributed by:

TRS Wholesale Limited
9B / 40 Waters Ave, Blenheim 7201, New Zealand
Postal Address : PO Box 162, Blenheim 7240, New Zealand
Telephone : +64 3 572 5150
Email: sales@trswholesale.co.nz | trsequipment.co.nz

Your local dealer: