

FMR V-SERIES SPRAYER 2300V GEN II



INNOVATION FOR GROWTH.

FMR V-SERIES SPRAYER 2300V GEN II

The Generation II V-Series Vineyard Sprayer takes a great concept and makes it even better! Building on the base of the original V-Series vine sprayer released in 2008, the Generation II machine introduces a number of innovations and developments, bringing additional benefits to owners and operators.

New features include:

- Tank design provides improved weight distribution for stability
- Boom system offers improved functionality and flexibility including hydraulic row width adjustment
- Tangential fan standardised at 1.8mt length for improved delivery in all canopies
- 'Wet boom' system with 8 roll-over nozzle bodies
- Pumps and valves slide or fold out, making regular servicing simple and easy
- Overall manoeuvrability and stability improved with overall height reduced and centre of mass lowered
- Improved heavy duty axle with suspension system
- Improved tank level indicator located on rear frame
- Optimised hydraulic system for greater efficiency and function
- Customised Bravo 300S Auto rate controller for improved operator comfort and control

FEATURES:

- 2300lt Composite tank
- 200lt fresh water for flushing & hand wash
- Hot dip galvanised chassis & boom
- Genuine Weber tangential fans with 8 nozzle wet boom
- Bravo 300 Automatic rate controller with hydraulic control for booms
- 100% hydraulic drive - just 45lt/min required
- 2 & 3-row options available
- Storage box option available
- Independent boom adjustment option for terraced vineyards

BENEFITS:

- Targeted delivery results in less off-target drift
- Tangential fan delivers a turbulent stream of high volume, low pressure air across a full length curtain, creating leaf movement and contributing to inner canopy penetration and even deposition to all target surfaces
- Improved operator safety and experience
- Longevity and reliability from strong, robust design
- Ease of cleaning and maintenance
- Fast connect and disconnect from tractor
- Developed, tested and proven in New Zealand & Australian vineyards

MODEL DIMENSIONS:

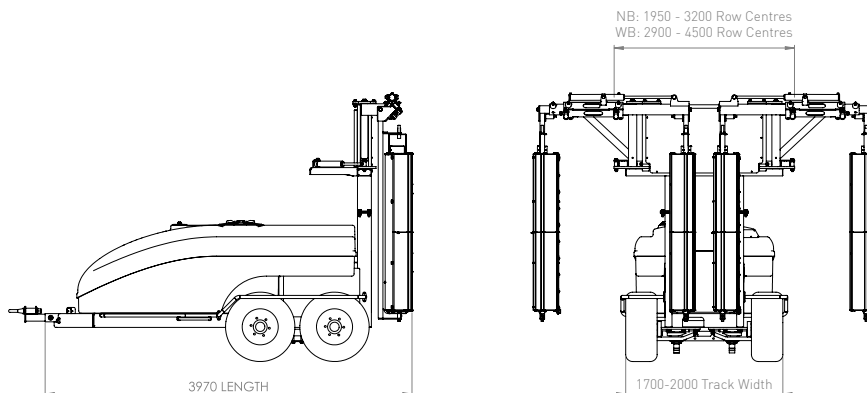

Fan with wet boom

FMR GROUP LIMITED NEW ZEALAND

2 Warwick Street, Mayfield, Blenheim 7201, New Zealand
Postal Address : PO Box 158, Blenheim 7240, New Zealand
Telephone : +64 3 572 5150 | Freephone: 0800 367 583
Email: info@fmrgroup.co.nz | FMRGROUP.CO.NZ

FMR GROUP LIMITED AUSTRALIA

53 Oborn Road, Mount Barker, South Australia 5251, Australia
Postal Address : PO Box 1059, Mount Barker 5251, Australia
Telephone : +61 8 8391 5947 | Freephone: 1800 269 773
Email: info@fmrgroup.com.au | FMRGROUP.COM.AU



FMR V-SERIES SPRAYER 2300VT GEN II



INNOVATION FOR GROWTH.

FMR V-SERIES SPRAYER 2300VT GEN II

The Generation II V-Series Vineyard Sprayer takes a great concept and makes it even better! Building on the base of the original V-Series vine sprayer released in 2008, the Generation II machine introduces a number of innovations and developments, bringing additional benefits to owners and operators.

New features include:

- Tank design provides improved weight distribution for stability
- Boom system offers improved functionality and flexibility including hydraulic row width adjustment
- Tangential fan standardised at 1.8mt length for improved delivery in all canopies
- 'Wet boom' system with 8 roll-over nozzle bodies
- Pumps and valves slide or fold out, making regular servicing simple and easy
- Overall manoeuvrability and stability improved with overall height reduced and centre of mass lowered
- Improved heavy duty tandem axle with suspension system
- Improved tank level indicator located on rear frame
- Optimised hydraulic system for greater efficiency and function
- Customised Bravo 300S Auto rate controller for improved operator comfort and control

FEATURES:

- 2300lt Composite tank
- 200lt fresh water for flushing & hand wash
- Hot dip galvanised chassis & boom
- Genuine Weber tangential fans with 8 nozzle wet boom
- Bravo 300 Automatic rate controller with hydraulic control for booms
- 100% hydraulic drive - just 45lt/min required
- 2 & 3-row options available
- Storage box option available
- Independent boom adjustment option for terraced vineyards

BENEFITS:

- Targeted delivery results in less off-target drift
- Tangential fan delivers a turbulent stream of high volume, low pressure air across a full length curtain, creating leaf movement and contributing to inner canopy penetration and even deposition to all target surfaces
- Improved operator safety and experience
- Longevity and reliability from strong, robust design
- Ease of cleaning and maintenance
- Fast connect and disconnect from tractor
- Developed, tested and proven in New Zealand & Australian vineyards

MODEL DIMENSIONS:

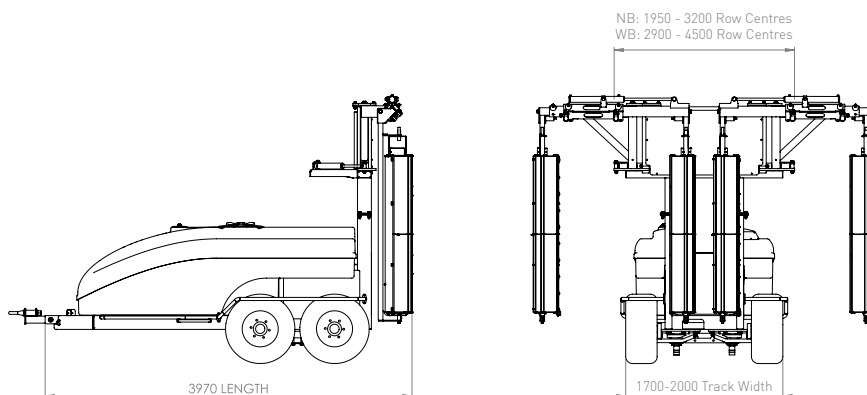

Fan with wet boom

FMR GROUP LIMITED NEW ZEALAND

2 Warwick Street, Mayfield, Blenheim 7201, New Zealand
Postal Address : PO Box 158, Blenheim 7240, New Zealand
Telephone : +64 3 572 5150 | Freephone: 0800 367 583
Email: info@fmrgroup.co.nz | FMRGROUP.CO.NZ

FMR GROUP LIMITED AUSTRALIA

53 Oborn Road, Mount Barker, South Australia 5251, Australia
Postal Address : PO Box 1059, Mount Barker 5251, Australia
Telephone : +61 8 8391 5947 | Freephone: 1800 269 773
Email: info@fmrgroup.com.au | FMRGROUP.COM.AU



FMR V-SERIES SPRAYER 3000VT GEN II



INNOVATION FOR GROWTH.

FMR V-SERIES SPRAYER 3000VT GEN II

The Generation II V-Series Vineyard Sprayer takes a great concept and makes it even better! Building on the base of the original V-Series vine sprayer released in 2008, the Generation II machine introduces a number of innovations and developments, bringing additional benefits to owners and operators.

New features include:

- Tank design provides improved weight distribution for stability
- Boom system offers improved functionality and flexibility including hydraulic row width adjustment
- Tangential fan standardised at 1.8mt length for improved delivery in all canopies
- 'Wet boom' system with 8 roll-over nozzle bodies
- Pumps and valves slide or fold out, making regular servicing simple and easy
- Overall manoeuvrability and stability improved with overall height reduced and centre of mass lowered
- Improved heavy duty tandem axle with suspension system
- Improved tank level indicator located on rear frame
- Optimised hydraulic system for greater efficiency and function
- Customised Bravo 300S Auto rate controller for improved operator comfort and control

FEATURES:

- 3000lt Composite tank
- 200lt fresh water for flushing & hand wash
- Hot dip galvanised chassis & boom
- Genuine Weber tangential fans with 8 nozzle wet boom
- Bravo 300 Automatic rate controller with hydraulic control for booms
- 100% hydraulic drive - just 45lt/min required
- 2 & 3-row options available
- Storage box option available
- Independent boom adjustment option for terraced vineyards

BENEFITS:

- Targeted delivery results in less off-target drift
- Tangential fan delivers a turbulent stream of high volume, low pressure air across a full length curtain, creating leaf movement and contributing to inner canopy penetration and even deposition to all target surfaces
- Improved operator safety and experience
- Longevity and reliability from strong, robust design
- Ease of cleaning and maintenance
- Fast connect and disconnect from tractor
- Developed, tested and proven in New Zealand & Australian vineyards

MODEL DIMENSIONS:

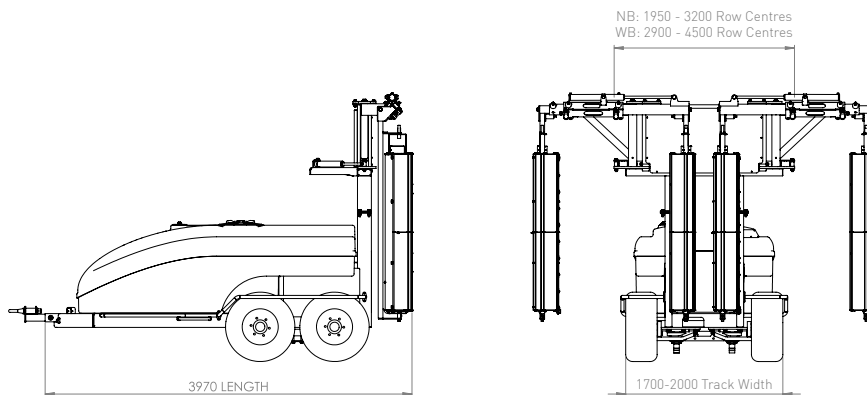

Fan with wet boom

FMR GROUP LIMITED NEW ZEALAND

2 Warwick Street, Mayfield, Blenheim 7201, New Zealand
Postal Address : PO Box 158, Blenheim 7240, New Zealand
Telephone : +64 3 572 5150 | Freephone: 0800 367 583
Email: info@fmrgroup.co.nz | FMRGROUP.CO.NZ

FMR GROUP LIMITED AUSTRALIA

53 Oborn Road, Mount Barker, South Australia 5251, Australia
Postal Address : PO Box 1059, Mount Barker 5251, Australia
Telephone : +61 8 8391 5947 | Freephone: 1800 269 773
Email: info@fmrgroup.com.au | FMRGROUP.COM.AU



FMR V-SERIES SPRAYER 4000VT GEN II



INNOVATION FOR GROWTH.

FMR V-SERIES SPRAYER 4000VT GEN II

The Generation II V-Series Vineyard Sprayer takes a great concept and makes it even better! Building on the base of the original V-Series vine sprayer released in 2008, the Generation II machine introduces a number of innovations and developments, bringing additional benefits to owners and operators.

New features include:

- Tank design provides improved weight distribution for stability
- Boom system offers improved functionality and flexibility including hydraulic row width adjustment
- Tangential fan standardised at 1.8mt length for improved delivery in all canopies
- 'Wet boom' system with 8 roll-over nozzle bodies
- Pumps and valves slide or fold out, making regular servicing simple and easy
- Overall manoeuvrability and stability improved with overall height reduced and centre of mass lowered
- Improved heavy duty tandem axle with suspension system
- Improved tank level indicator located on rear frame
- Optimised hydraulic system for greater efficiency and function
- Customised Bravo 300S Auto rate controller for improved operator comfort and control

FEATURES:

- 4000lt Composite tank
- 200lt fresh water for flushing & hand wash
- Hot dip galvanised chassis & boom
- Genuine Weber tangential fans with 8 nozzle wet boom
- Bravo 300 Automatic rate controller with hydraulic control for booms
- 100% hydraulic drive - just 45lt/min required
- 2 & 3-row options available
- Storage box option available
- Independent boom adjustment option for terraced vineyards

BENEFITS:

- Targeted delivery results in less off-target drift
- Tangential fan delivers a turbulent stream of high volume, low pressure air across a full length curtain, creating leaf movement and contributing to inner canopy penetration and even deposition to all target surfaces
- Improved operator safety and experience
- Longevity and reliability from strong, robust design
- Ease of cleaning and maintenance
- Fast connect and disconnect from tractor
- Developed, tested and proven in New Zealand & Australian vineyards

MODEL DIMENSIONS:

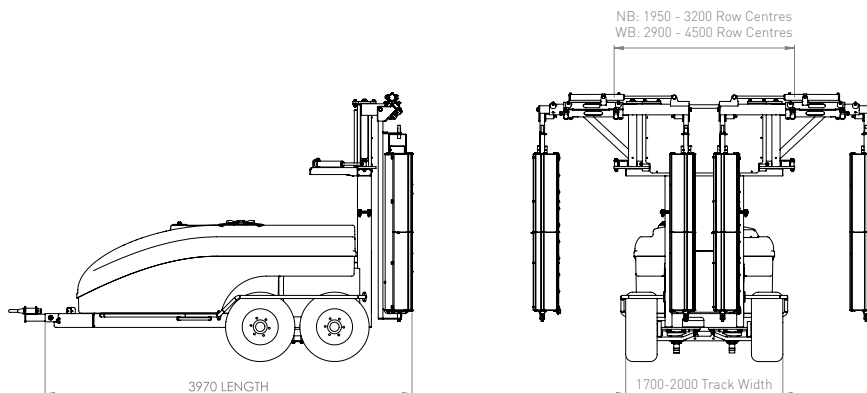

Fan with wet boom

FMR GROUP LIMITED NEW ZEALAND

2 Warwick Street, Mayfield, Blenheim 7201, New Zealand
Postal Address : PO Box 158, Blenheim 7240, New Zealand
Telephone : +64 3 572 5150 | Freephone: 0800 367 583
Email: info@fmrgroup.co.nz | FMRGROUP.CO.NZ

FMR GROUP LIMITED AUSTRALIA

53 Oborn Road, Mount Barker, South Australia 5251, Australia
Postal Address : PO Box 1059, Mount Barker 5251, Australia
Telephone : +61 8 8391 5947 | Freephone: 1800 269 773
Email: info@fmrgroup.com.au | FMRGROUP.COM.AU

