



MF DM SERIES

Mowers & Mower Conditioners

Innovative and Efficient Mowers and Mower Conditioners



FROM MASSEY FERGUSON



Page 04
MF Farmer DM Series: Disc mowers

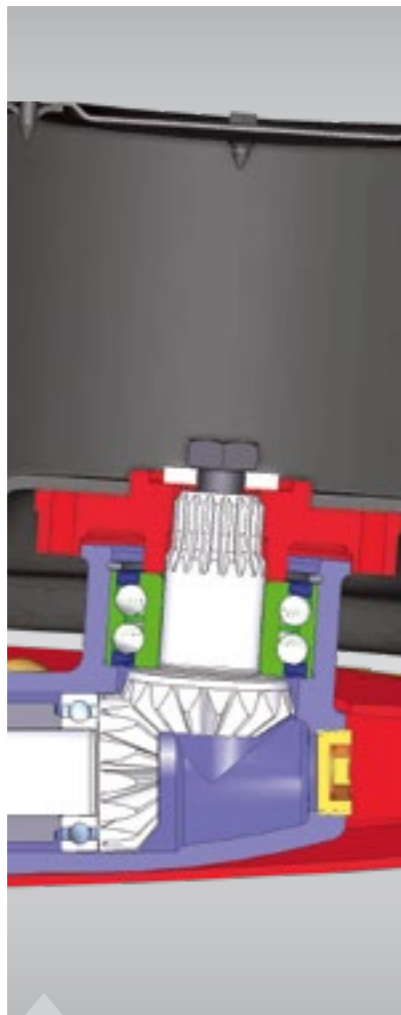

Page 06
MF Professional DM Series: Disc mowers and mower conditioners



Page 07
driveGUARD®



Page 08
MF Disc Mowers:
Rear-mounted mower



Page 14
Specifications

Contents

- 04 MF Farmer DM Series: Disc mowers
- 06 MF Professional DM Series: Disc mowers and mower conditioners
- 07 **driveGUARD®**
- 08 MF Disc Mowers: Rear-mounted disc mower
- 09 MF Disc Mowers: Rear-mounted, Three-point linkage, centre support
- 10 MF Disc Mower: Rear mounted, centre support, vertical folding
- 11 MF Front-mounted Disc Mowers and Disc Mower Conditioners
- 12 MF Butterfly Disc Mower Conditioner combination
- 14 Specifications

MF Farmer Series: Disc mowers

The MF DM 164, MF DM 205, MF DM 246, MF DM 287 and MF DM 328 provide a sturdy and economical solution to the small and medium size farmer without compromising on quality and finish. Ideally suited to farmers with lower horsepower tractors or a limited amount of mowing to carry out, these mowers boast a host of features you would expect to find on larger, more expensive machines.



MF DM 164, MF DM 205, MF DM 246, MF DM 287 and MF DM 328 features include:

- A PTO shaft with a free wheel clutch, which transfers power through a V belt from the tractor to the in-line cutterbar.
- Each individual cutting head is fitted with shear pin protection, preventing damage in case obstacles are hit. These pins can easily be replaced in the field.
- The flat profile is ideal for heavy crops and, combined with the standard stone guard and large hardened skid, ensures years of trouble-free service.
- Built to perform under the most difficult conditions.
- Provides an exact cut and high material flow without material build-up, leaving fluffy swaths and high quality forage.



Key Features & Benefits

- Suitable for multiple applications
- Suitable for use with smaller tractors
- Low power requirement
- Spring mounted cutter bar – Low ground pressure, gentle on crop



Side hitch attachment: makes mowing possible on sloping terrain

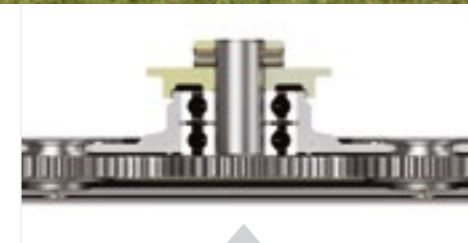

Solid bearing mounting – high level of reliability when in use



Shock absorbing V-belt drive



Durable oil bath cutter bar

Low weight – wide coverage

Massey Ferguson disc mowers with spur gear drive ensure a long working life and low operating costs. The lightweight construction maximises the yield, even with smaller tractors wider working widths can be used. The simple low maintenance design of these mowers also make sure downtime is kept to a minimum.

Precise mowing – even under difficult conditions

The precision engineered gear bed cutter bar, with elliptical discs, rotating swathformers and robust conveyor drums make sure it is possible to achieve a clean cutting pattern and good throughput even on difficult terrain.

Key features of our cutter bar

Low wear and simple to maintain. The bolted cutter bar has all components mounted in the base plate with a simple-to-remove cover plate.

- Equipped to handle all loads due to the robust construction with high quality materials
- Superior Massey Ferguson blades for an extremely high quality of cut
- High-quality roller bearings used throughout to ensure smooth running gears and long life
- Full sealing of the complete cutter bar

MF Professional Series: Features

Disc mowers and mower conditioners

Designed for contractors and larger farms and built to tackle the big jobs, the Professional Series offers many exclusive features that provide high performance and low operating costs.

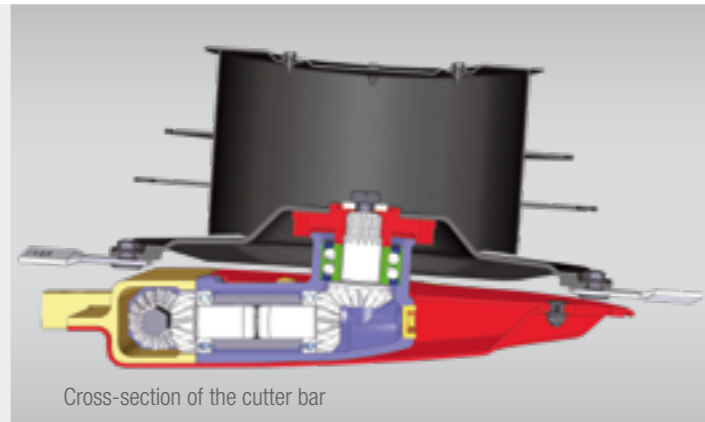

Cross-section of the cutter bar

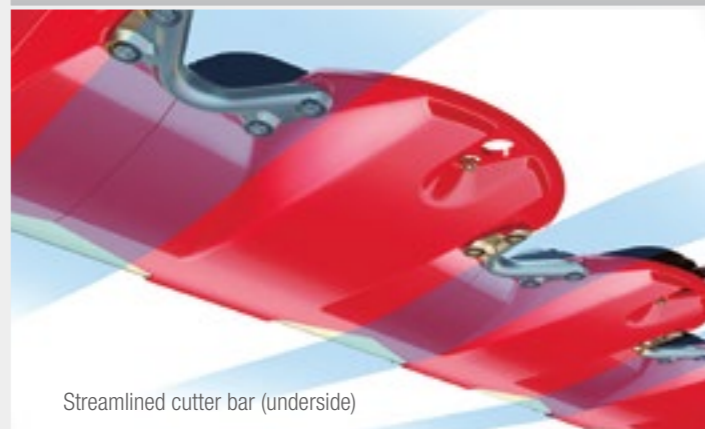

Streamlined cutter bar (underside)

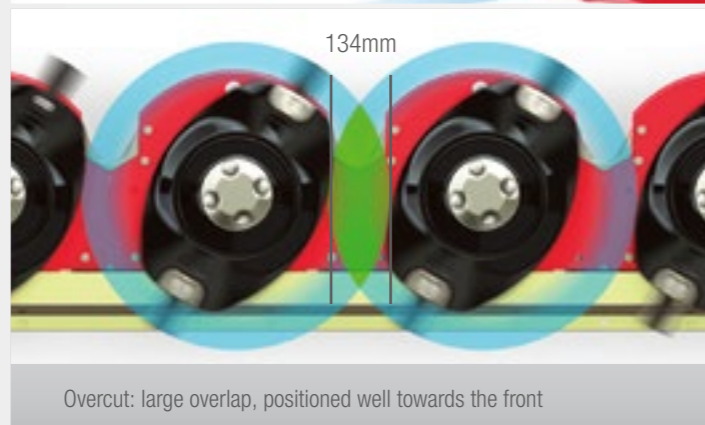

Overcut: large overlap, positioned well towards the front

The secret to a perfect cut

The compact angle drive

At the heart of this system is a continuous, large-dimensioned hexagonal shaft and a robust angular gearbox under each mower disc. This results in even power distribution to all mower discs and the smoothing of torque loads. The wear on components is significantly lower when compared to a conventional spur gear cutter bar. The components are mounted to a robust yet flexible unit. The Massey Ferguson disc mowers with compact angle drive are durable with a low PTO power requirement, ensuring high output cost efficient mowing at all times.

Ergonomics of the cutter bar

The ergonomics of the cutter bar determine whether you will harvest quality forage. The engineers at Massey Ferguson have succeeded in developing a perfectly streamlined cutter bar with the optimum profiles on the underside. As a result, even in adverse conditions, the formation of mounds of soil in field forage crops or on wet land is prevented. The soil is cleanly separated from the forage and flows away under the cutter bar. With a Massey Ferguson cutter bar, you can continue to work when others have had to give up or have not even been able to start working.

Knife overlap

A perfect cut is achieved due to the large overlap of the mower discs, which are positioned well towards the front. Massey Ferguson mowers use large mower discs and their special shape means that they can handle large volumes of forage – an important aspect, especially for heavy, lying material. A clean cutting pattern is guaranteed with a Massey Ferguson mower!

Features of the compact angle drive

Everything is well thought-out for a high level of operational reliability and low operating costs

A great deal of engineering expertise has gone into the design of the cutter bar. For example, the main hexagonal drive shaft was designed with a predetermined breaking point, which interrupts the flow of power between the cutter bar and the tractor, in the event of a sudden heavy overload, preventing expensive and time consuming repairs. Bolt-on skids and quick-change knives reduce downtime. With lifetime oil filling, the cutter bar is largely maintenance-free and the lubrication of the cutter bar is ensured in all mowing situations.



Bolted structure



Hexagonal shaft for efficient transmission of power



Streamline cutter bar (underside)



Quick change knives

Axial or paired running – anything is possible

Due to the compact angle drive being bolted, you can change the direction of rotation of each module to meet your individual mowing needs – even after many years.

The mower discs are converted from axial running to paired running by simply switching the angle drive – all without any additional components.

You can flexibly adapt your Massey Ferguson mower to changing general conditions. Whatever comes your way, you always have the right mowing technology.



Paired running

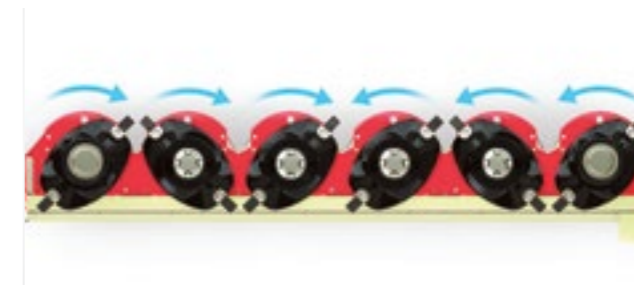

Axial running

drive GUARD®

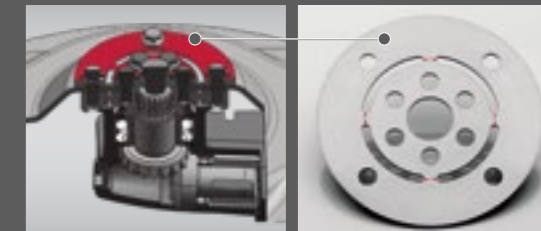

Every farmer knows from experience that foreign objects accidentally drawn into the mower can cause significant damage.

Massey Ferguson prevents precisely this kind of damage with driveGUARD® – the industry leading overload protection system.



Better protected than ever

When the mower disc becomes jammed by a foreign object the driveGUARD® shears off at the predetermined breaking points.

This interrupts the power train and the mower disc turns freely.



Nothing is more cost-effective

driveGUARD® offers the customer extremely cost-effective and reliable protection because, only the throw-away overload disc will have to be replaced if the need arises.

MF Disc Mowers: Rear-mounted disc mower

MF DM 204, MF DM 255 P, MF DM 306 P & MF DM 357 P

The MF Professional Series disc mowers feature individual compact angular gears that provide an extremely smooth power transfer to all discs, resulting in less wear than a conventional gear drive and ensuring a longer and more reliable cutter bar life. The wedge-shaped bar provides the added benefit of a low cut and the 'Big Disc' design ensures a large overlap, which results in a clean cut even when faced with high volume and difficult crops.

The modular design enables quick and easy servicing in the field, should it be required.



Rear-mounted three-point side attachment

Lateral suspension with a controlled lifting linkage results in a compact transport position and low transport height. A quick change knife system is standard on the Professional Series mowers, increasing the efficiency of operation.

As an option, the MF DM 255 P can be quickly and easily retrofitted with a roller (RC) or tine conditioner (KC), while the MF DM 306 P can be retrofitted with a KC tine conditioner.

A sturdy exterior support guarantees the long working life of the protective covers thus increasing the operational safety of the machine.



Roller conditioner

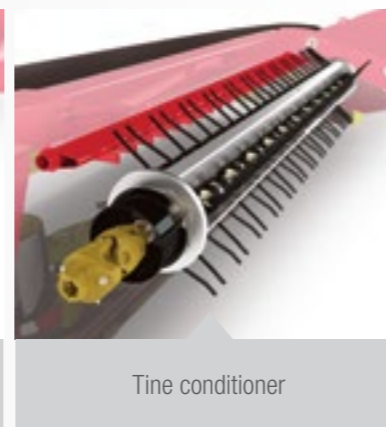

Tine conditioner

MF Disc Mowers: Rear-mounted. Three-point linkage, centre support

MF DM 306 TL, MF DM 306 TL-KC, MF DM 306 TL-RC, MF DM 357 TL, MF DM 357 TL-KC, MF DM 408 TL & MF DM 459 TL

- Rear-mounted mower for medium power tractor classes
- Hydro-pneumatic suspension
- Ease of handling

Hydro-pneumatic suspension system – TurboLift system

Infinitely variable ground pressure control, with the ability to change ground pressure on-the-move as field conditions vary.

- Free-floating cutting
- Patented sliding guide
- Adaptable to a variety of conditions
- Improved cutting quality
- Reduced load on the support frame, support tube and three-point linkage
- Gentle on the turf sward
- Reduced forage contamination
- Precise support and guidance of the mowing bar
- Very good adjustment to the ground

The support frame – the backbone of any mower

The cutter bar is supported and guided by the support frame. This is manufactured from high-quality, warp-resistant steel and is designed for extremely high loads.



TurboLift system



Sliding guide

MF Disc Mowers: Rear Mounted. Centre support, vertical folding

**MF DM 265 TL-V, MF DM 316 TL-V, MF 316 TL-V-KC,
MF 316 TL-V-RC, MF DM 367 TL-V, MF DM 367 TL-V-KC,
MF DM 367 TL-V-RC**

- Rear mounted centre support mower with vertical folding
- Hydro-pneumatic suspension.
- SafetySwing protection system
- Low profile spur gear cutter bar

Centre support with vertical folding.

MF DM TL-V mowers fold vertically for transporting within the machine's centre of gravity and provide excellent weight distribution of the tractor / mower combination. With compact transport dimensions of less than 3m wide and a transport height of lower than 4m these machines are ideally suited where road transport is a regular requirement.

Hydro-pneumatic suspension system.

Turbolift system for infinitely variable ground pressure control. Adapts to varying field conditions and eliminates damage to the sward.

SafetySwing protection system.

Prevents damage in the event of hitting an obstruction by moving backwards and upwards. Automatically re-engages into the working position through its own weight. Additionally MF TL-V mowers feature all round plastic bumpers to protect against minor damage and a hydraulically foldable end panel to reduce height when in the transport position.



Compact transport dimensions



Safety swing

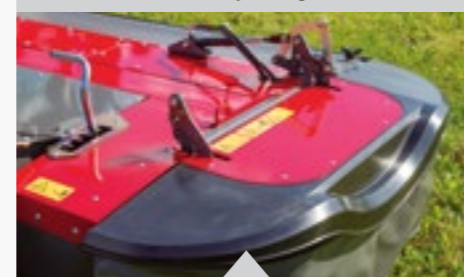

Simple conditioner adjustment

MF Disc Mowers and Mower Conditioners: Front-mounted - Trailing linkage or pivoting headstock

MF DM 306 FZ & MF DM 306 FP

- Perfect for operating in mower combinations
- Hydraulic movement system for harvesting without losses
- Three-dimensional sensing of ground contours

Spring parallelogram

- Optimally located
- Minimal spring contraction during oscillating movement of the mower unit
- Low ground pressure

Conditioning process

- Tine and roller conditioners available
- Gentle forage treatment
- No crushing
- Less loss due to crumbling compared to flail conditioners

Conditioner intensity

- Adaptable to a variety of conditions
- Easily adjustable to four positions without tools
- Easy to replace individual elements

Simple direct-drive concept

- Overload protection
- Low weight
- Easy to operate with little additional power demand

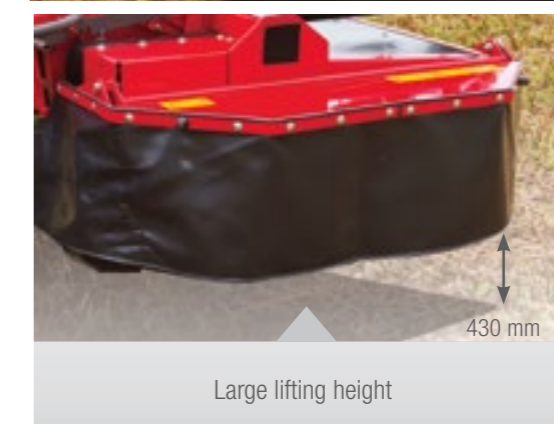

Large lifting height



Ample pivot travel

MF Disc Mowers and Mower Conditioners: Butterfly

MF DM 8312 TL-KC, MF DM 8312 TL-RC & MF DM 9314 TL-KC

- Butterfly mower conditioners 8.3 and 9.3 metres
- Three-point linkage attachment
- Hydro pneumatic suspension
- SafetySwing anti-collision device

Mower units are mounted at their centre of gravity

- Adapts very well to the ground contours
- Reduced load on tractor lift arms

Trailed mower – pulling is easier than pushing

- Soil conserving
- Fuel saving

Constant, continuously variable ground surface pressure

- Adaptable to a variety of conditions
- **SafetySwing** anti-collision device
- Each mower unit avoids obstructions independently
- Mower unit folds backwards and upwards
- Re-engagement into working position through its own weight

Contact pressure adjustable while driving

- Low ground impact
- No forage contamination

Free-floating cutting

- Gentle on turf sward
- Reduced forage contamination



MF DM 8312 TL-KC RC & MF DM 9314 TL-KC

Rear-mounted Butterfly

The MF DM 8312 rear-mounted 3PL butterfly disc mower with KC or RC tine rotor conditioner is a perfect companion to the front-mounted MF DM 306 FZ mower conditioner with trailing linkage. Working in tandem, the two provide a total cutting width of 8.30 m, allowing you to cover more ground faster.

The MF DM 8312 features free-floating cutting, which reduces the load on the support frame, support tube and the 3-point linkage hitch. It allows for improved cutting quality on uneven ground thanks to its

TurboLift-system (TL), which enables hydro-pneumatic discharge and continuous adjustment of pressure on the cutter bar.

The MF DM 8312 TL-KC RC and MF DM 9314 TL-KC mower is also fitted with impact **SafetySwing** protection, which can independently fold back and up around the slanting axle should an obstacle be hit.

If an incident occurs, the mower will return to its working position under its own weight, saving time without the need to reverse.

Both mowers feature one-lever operation for quick change at the headlands, making the transition from working to turning fast and simple.



MF DM 8312 EL TL-KCB, MF DM 8312 EL TL-RCB & MF DM 9314 EL TL-KCB

Mower combination with conveyor belts and ISOBUS control system

Advanced machine technology coupled with a state-of-the-art ISOBUS equipment control system, makes this mower combination with conveyor belt stand out from the rest. A working width of 8.30 m or 9.30 m allows large volumes of forage to be processed efficiently. For the MF DM 9314 TL-KCB, a particularly wide conveyor belt (940 x 2,700 mm) has been developed that can handle larger volumes of forage with ease, and continuously operate at higher working speeds.

- Hydraulic floating mower units – TurboLift system
- **SafetySwing** impact guard
- Trailed cutter bar hitch attachment – pulling is easier than pushing
- Operation of all mower functions via the ISOBUS control system
- Comprehensive speed monitoring of rotating parts
- Wide conveyor belt with integrated hydraulic lateral movement
- Central, single or partial swath delivery to conveyor belts that can be raised individually
- ComfortChange quick-change blade system as standard, to safely replace blades without losing time
- Retrofit kit available for non-ISOBUS-compatible tractors
- Active ground pressure control



Specifications

MF Disc Mowers

Model	MF DM 164	MF DM 205	MF DM 246 / MF DM 246 ISL	MF DM 287/ MF DM 287 ISL	MF DM 328 ISL	MF DM 204	MF DM 255 P	MF DM 306 P	MF DM 357 P
Configuration	3 pt - Side Mount	3 pt - Side Mount	3 pt - Side Mount	3 pt - Side Mount	3 pt - Side Mount	3 pt - Side Mount	3 pt - Side Mount	3 pt - Side Mount	3 pt - Side Mount
Width (m)	1.66	2.06	2.42	2.82	3.18	2.05	2.55	3.00	3.50
Min. pwr (hp)	30	41	50	60	72	49	54	61	68
Weight (kg)	372	407	437 / 510	475 / 550	570	612	630	724	798
PTO (rpm)	540	540	540	540	540	540/1000	540/1000	540/1000	540/1000
Discs	4	5	6	7	8	4	5	6	7
KC Conditioner	-	-	-	-	-	○	○	○	-
RC Conditioner	-	-	-	-	-	○	○	-	-

MF Three-point linkage mounted disc mowers with centre support

Model	MF DM 306 TL	MF DM 357 TL	MF DM 408 TL	MF DM 459 TL
Working width approx. m	3	3.50	4.00	4.50
Transport width approx. m	2.3	2.3	2.3	2.3
Transport length approx.m	4.65	5.15	5.60	6.10
Mower discs	6	7	8	9
Blades per disc	2	2	2	2
Swath width approx. m	2.3	2.8	3.3	3.8
Power demand approx. kW/hp	55/75	65/88	72/99	84/115
Necessary hydraulic outlets	1 X SAV, 1 X DAV	1 X SAV, 1 X DAV	1 X SAV, 1 X DAV	1 X SAV, 1 X DAV
PTO rpm	540/1000	540/1000	540/1000	540/1000
Overrunning clutch	●	●	●	●
Weight approx. kgs	875	950	980	1,100
KC Conditioner	○	○	-	-
RC Conditioner	○	-	-	-

MF Disc Mowers - Centre Support, Vertical Folding

Model	MF DM 265 TL-V	MF DM 316 TL-V	MF DM 367 TL-V
Working width (m)	2.6	3.1	3.6
Mower discs	5	6	7
Swath width approx. m	0.7 – 1.8	0.8 – 2.3	1.0 – 2.8
PTO (rpm)	1000	1000	1000
Min. power hp (KC/RC model)	75	85	95
Transport width (m)	2.2	2.5	2.8
Transport height (m)	3.17	3.58	3.99
Weight approx. kgs	950	1,050	1,200
KC Conditioner	○	○	○
RC Conditioner	○	○	○

MF Mower Combination

Model	MF DM 8312 TL	MF DM 9314 TL	MF DM 8312 EL TL-KCB	MF DM 8312 EL TL-RCB	MF DM 9314 EL TL-KCB
Working width approx. m	8.3	9.3	8.3	8.3	9.3
Transport width approx. m	2.78	2.78	2.78	2.78	2.78
Transport height approx. m	3.73	3.9	3.73	3.73	3.9
Mower discs	2 X 6	2 X 7	2 x 6	2 x 6	2 X 7
Blades per disc	2	2	2	2	2
Swath width approx. m	2 X 1.45 - 2.25	2 X 1.85 - 3.25	1.8 - 2.6	1.8 - 2.6	2 X 1.80 - 3.00
Power demand approx. kW/hp	132/180	155/200	145/200	141/182	168/228
Necessary hydraulic outlets	2 X SAV, 1 X DAV	2 X SAV, 1 X DAV	1 X Load Sensing	1 X Load Sensing	1 X Load Sensing
PTO rpm	1000	1000	1000	1000	1000
Overrunning clutch	●	●	●	●	●
Warning panels	●	●	●	●	●
Electrical lightning	●	●	●	●	●
Weight approx. kgs	2,410	2,830	3,200	3,300	3,450
KC Conditioner	○	○	●	-	●
RC Conditioner	○	-	-	●	-

MF Front-Mounted

Model	MF DM 254 FP / FP-S	MF DM 306 FP	MF DM 306 FP-K	MF DM 306 FP-SL	MF DM 306 FZ
Configuration	Alpine	Pivoting Headstock	Pivoting Headstock	Pivoting Headstock	Trailing Linkage
Width (m)	2.5	3	3	3	3
Min. pwr (hp)	38	75	75	75	75
Weight (kg)	474 / 504	734	694	854	930
PTO (rpm)	1000	1000	1000	1000	1000
Discs	4	6	6	6	6
KC Conditioner	-	○	○	○	○
RC Conditioner	-	○	-	-	○



MASSEY FERGUSON
A world of experience. Working with you.



Web: www.MasseyFerguson.com.au

Facebook: www.Facebook.com/MasseyFergusonGlobal

Twitter: [Twitter.com/MF_EAME](https://twitter.com/MF_EAME)

Instagram: [Instagram.com/MasseyFergusonGlobal](https://www.instagram.com/MasseyFergusonGlobal)

YouTube: www.YouTube.com/MasseyFergusonGlobal

Blog: Blog.MasseyFerguson.com



MASSEY FERGUSON® is a worldwide brand of AGCO.
© AGCO Limited. 2017 | A-A-16593/1117 | English/1117

11/18

Every effort has been made to ensure that the information contained in this publication is as accurate and current as possible. However, inaccuracies, errors or omissions may occur and details of the specifications may be changed at any time without notice. Therefore, all specifications should be confirmed with your Massey Ferguson Dealer or Distributor prior to any purchase.

